

WARDHAN EXTRUSION

Round Tube

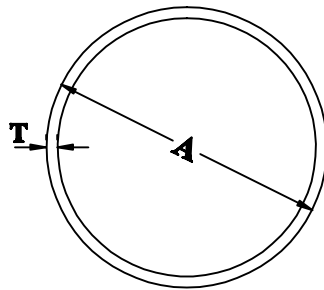

Sr. no.	Section No.	A	T	Wt. Rang /12'
1	1001	Ø 32.00	3.00	2.700 To 2.900 Kg
2	1002	Ø 38.00	3.30	3.500 To 3.700 Kg
3	1003	Ø 38.00	4.90	5.000 To 5.200 Kg
4	1004	Ø 52.00	2.07	3.180 To 3.380 Kg
5	1005	Ø 18.00	1.10	0.570 To 0.770 Kg
6	1006	Ø 18.00	1.28	0.665 To 0.865 Kg
7	1007	Ø 18.00	1.43	0.730 To 0.930 Kg

Glazing Clip

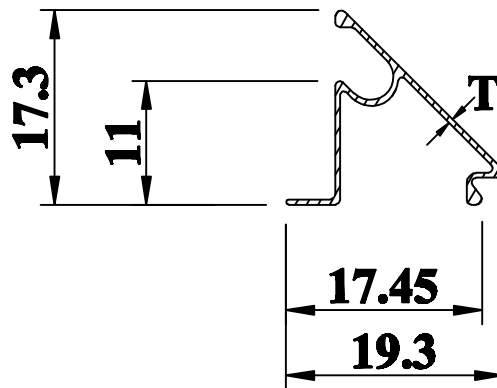

Sr. no.	Section No.	A	T	Wt. Rang /12'
1	1085	17.30	0.4	0.180 To 0.250 Kg

WARDHAN EXTRUSION

Glazing Plate

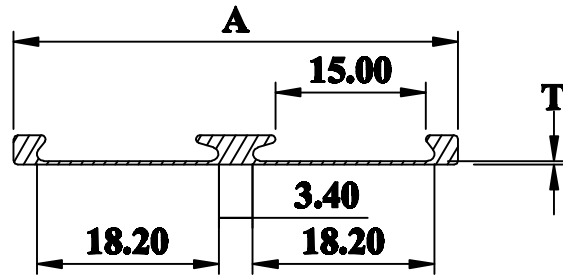

Sr. no.	Section No.	A	T	Wt. Rang /12'
1	1101	44.45	0.36	0.400 To 0.550 Kg

Single Partition

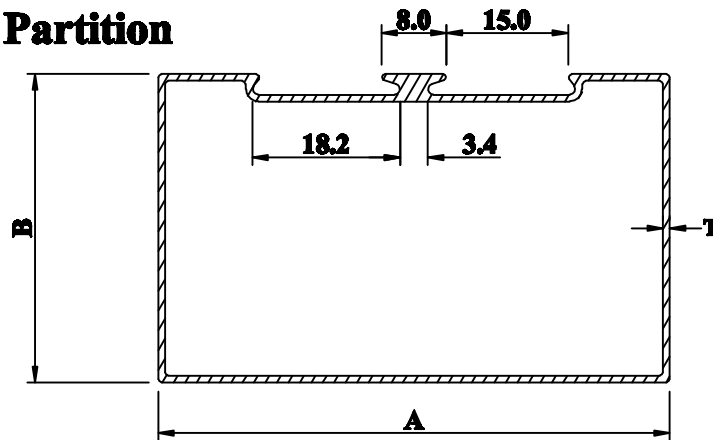

Sr. no.	Section No.	A	B	T	Wt. Rang /12'
1	1120	63.0	38.0	0.82	1.800 To 1.900 Kg
2	1121	63.0	38.0	0.97	2.100 To 2.200 Kg
3	1122	63.0	38.0	1.02	2.200 To 2.300 Kg
4	1123	63.0	38.0	1.08	2.300 To 2.400 Kg
5	1124	63.0	38.0	1.14	2.400 To 2.500 Kg
6	1125	63.0	38.0	1.45	3.000 To 3.200 Kg
7	1126	100.0	25.0	1.16	3.000 To 3.200 Kg
8	1127	100.0	44.0	1.08	3.200 To 3.350 Kg

WARDHAN EXTRUSION

Double Partition

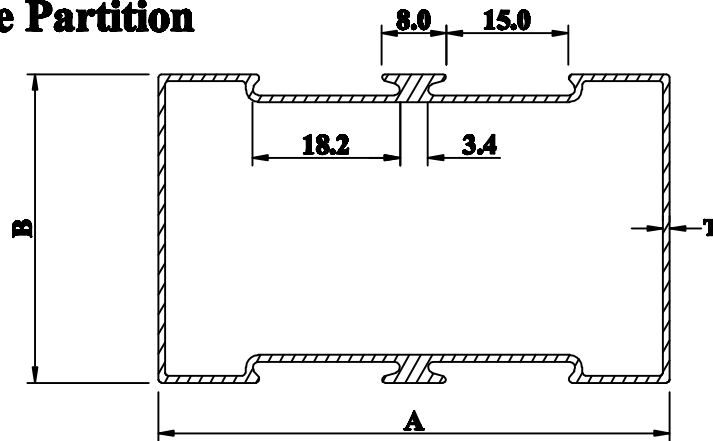

Sr. no.	Section No.	A	B	T	Wt. Rang /12'
1	1141	63.0	38.0	0.74	1.800 To 1.900 Kg
2	1142	63.0	38.0	0.95	2.250 To 2.350 Kg
3	1143	63.0	38.0	1.02	2.400 To 2.500 Kg
4	1144	63.0	38.0	1.32	3.000 To 3.200 Kg
5	1145	100.0	25.0	1.06	3.000 To 3.200 Kg
6	1146	100.0	44.0	1.02	3.250 To 3.400 Kg

D.M.S

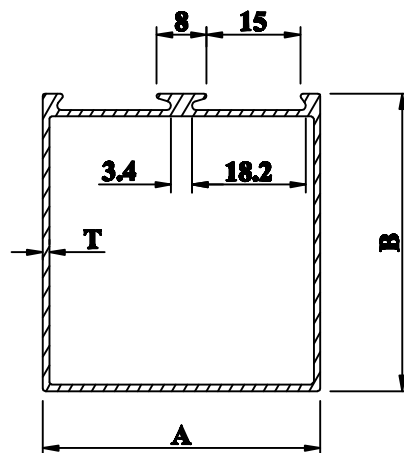

Sr. no.	Section No.	A	B	T	Wt. Rang /12'
1	1160	44.45	47.50	1.06	2.100 To 2.250 Kg
2	1161	44.45	83.50	1.12	3.000 To 3.250 Kg

WARDHAN EXTRUSION

D.M.D

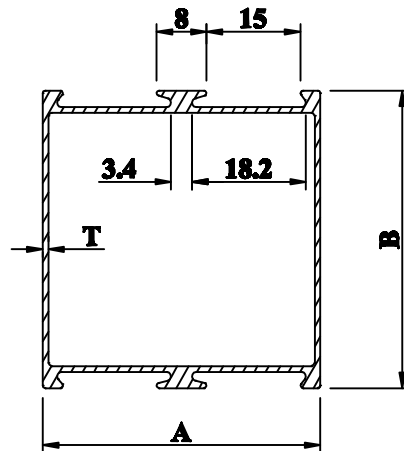

Sr. no.	Section No.	A	B	T	Wt. Rang /12'
1	1170	44.45	47.50	0.91	2.100 To 2.250 Kg
2	1172	44.45	83.50	1.02	3.000 To 3.250 Kg
3	1173	44.45	83.50	1.70	4.980 To 5.180 Kg
4	1174	44.45	47.50	1.10	2.500 To 2.700 Kg
5	1175	44.45	47.50	1.20	2.700 To 3.000 Kg

D.V

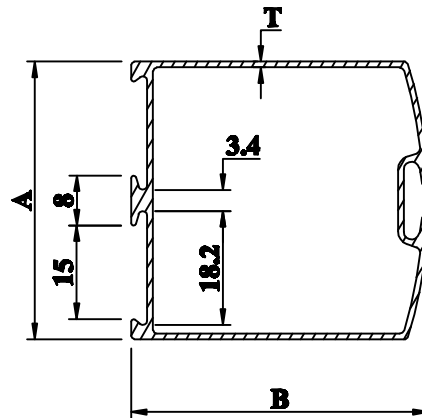

Sr. no.	Section No.	A	B	T	Wt. Rang /12'
1	1180	44.45	47.50	1.12	2.300 To 2.450 Kg
2	1181	44.45	83.50	1.05	3.000 To 3.250 Kg

WARDHAN EXTRUSION

DOOR TOP

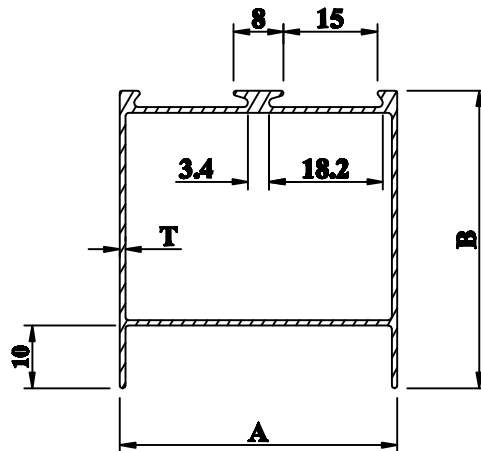

Sr. no.	Section No.	A	B	T	Wt. Rang /12'
1	1170	44.45	47.50	1.05	2.100 To 2.250 Kg
2	1172	44.45	83.50	1.12	3.000 To 3.250 Kg
3	1173	44.45	47.50	1.40	2.800 To 3.000 Kg
4	1174	44.45	83.50	1.86	4.920 To 5.120 Kg
5	1175	44.45	83.50	1.710	4.500 To 4.700 Kg

3/4" Handle

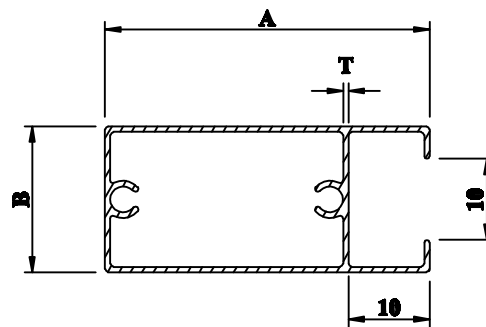

Sr. no.	Section No.	A	B	T	Wt. Rang /12'
1	1180	40.0	18.0	0.72	0.950 To 1.050 Kg
2	1181	40.0	18.0	0.82	1.100 To 1.200 Kg
3	1182	40.0	18.0	0.90	1.200 To 1.300 Kg
4	1183	40.0	18.0	1.02	1.350 To 1.450 Kg

WARDHAN EXTRUSION

3/4" Interlock

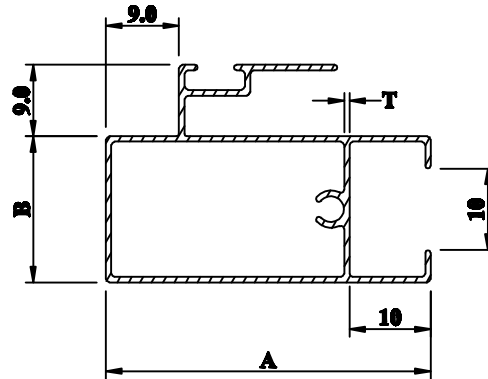

Sr. no.	Section No.	A	B	T	Wt. Rang /12'
1	1190	40.0	18.0	0.78	1.200 To 1.300 Kg
2	1191	40.0	18.0	0.86	1.350 To 1.450 Kg
3	1192	40.0	18.0	0.95	1.450 To 1.550 Kg

3/4" Top Bottom

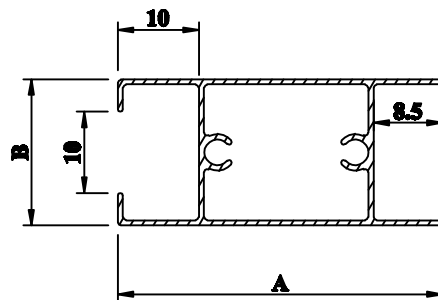

Sr. no.	Section No.	A	B	T	Wt. Rang /12'
1	1200	40.0	18.0	0.72	0.950 To 1.050 Kg
2	1201	40.0	18.0	0.82	1.100 To 1.200 Kg
3	1202	40.0	18.0	0.94	1.250 To 1.350 Kg

WARDHAN EXTRUSION

3/4" Top Bottom

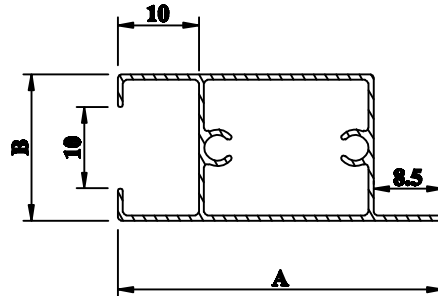

Sr. no.	Section No.	A	B	T	Wt. Rang /12'
1	1210	40.0	18.0	0.92	1.150 To 1.250 Kg

3/4" Middle

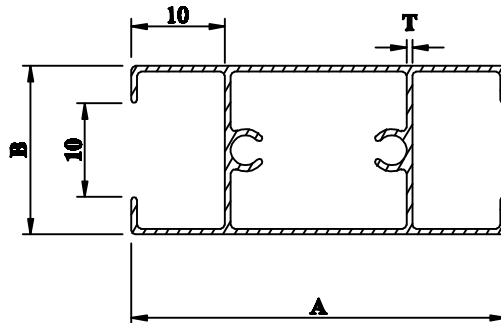

Sr. no.	Section No.	A	B	T	Wt. Rang /12'
1	1220	40.0	18.0	0.68	0.950 To 1.050 Kg
2	1221	40.0	18.0	0.79	1.100 To 1.200 Kg
3	1222	40.0	18.0	0.95	1.300 To 1.400 Kg
4	1223	40.0	18.0	0.98	1.400 To 1.500 Kg

WARDHAN EXTRUSION

2x1 Handle

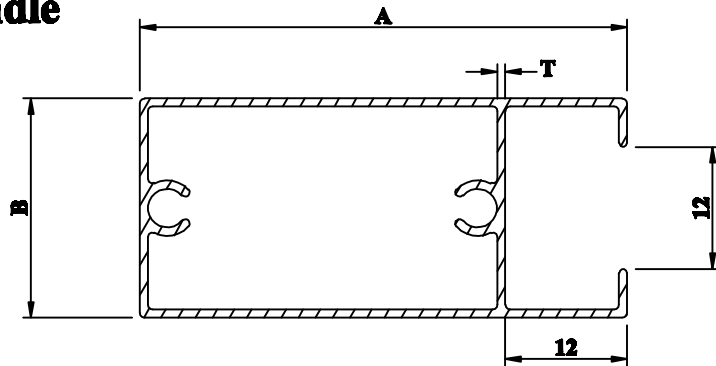

Sr. no.	Section No.	A	B	T	Wt. Rang /12'
1	1230	50.0	25.0	0.74	1.300 To 1.400 Kg
2	1231	50.0	25.0	0.82	1.450 To 1.550 Kg
3	1232	50.0	25.0	0.90	1.600 To 1.750 Kg

2x1 Top Bottom

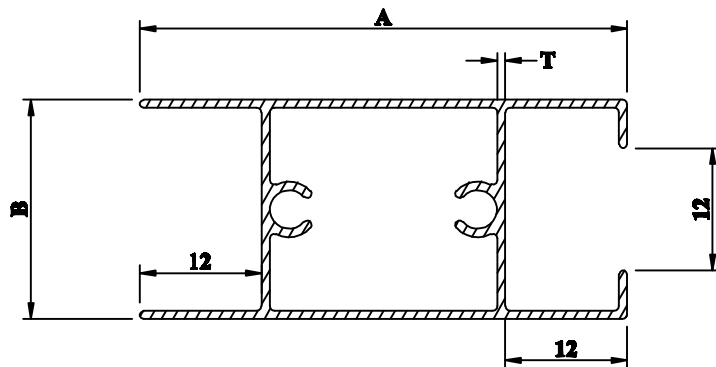

Sr. no.	Section No.	A	B	T	Wt. Rang /12'
1	1240	40.0	18.0	0.71	0.950 To 1.050 Kg
2	1241	40.0	18.0	0.80	1.400 To 1.500 Kg
3	1242	40.0	18.0	0.91	1.500 To 1.600 Kg

WARDHAN EXTRUSION

2x1 Top Bottom - S/L

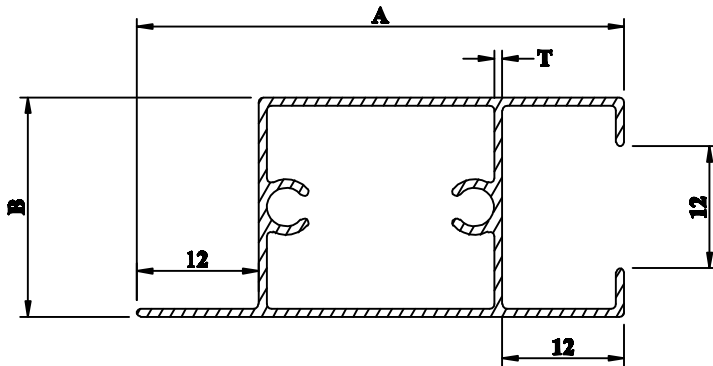

Sr. no.	Section No.	A	B	T	Wt. Rang /12'
1	1250	50.0	25.0	0.88	1.450 To 1.550 Kg

2x1 Middle

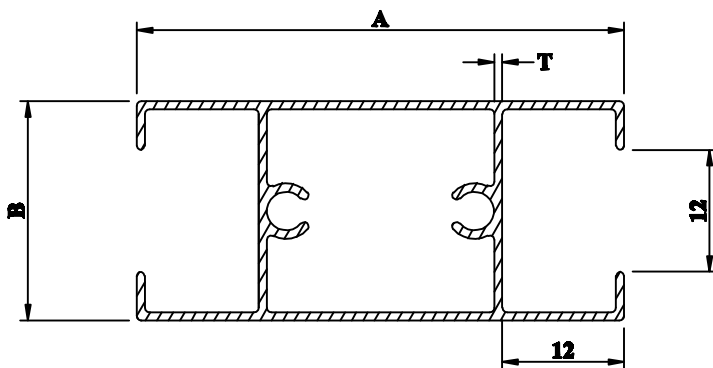

Sr. no.	Section No.	A	B	T	Wt. Rang /12'
1	1250	50.0	25.0	0.76	1.450 To 1.550 Kg

WARDHAN EXTRUSION

60 x 18 Handle

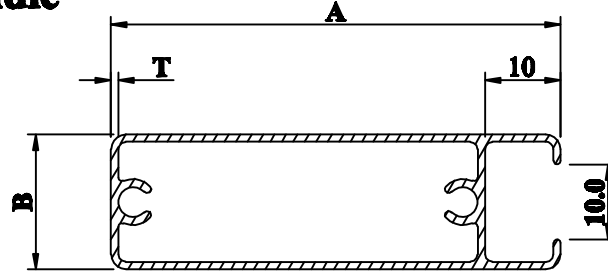

Sr. no.	Section No.	A	B	T	Wt. Rang /12'
1	1260	60.0	18.0	0.98	1.700 To 1.850 Kg

60 x 18 Interlock

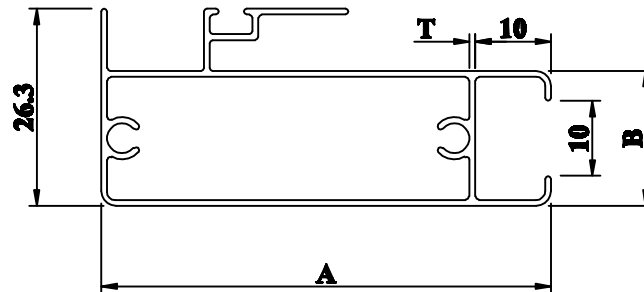

Sr. no.	Section No.	A	B	T	Wt. Rang /12'
1	1265	60.0	18.0	0.84	1.800 To 1.950 Kg

60 x 18 B.T.B

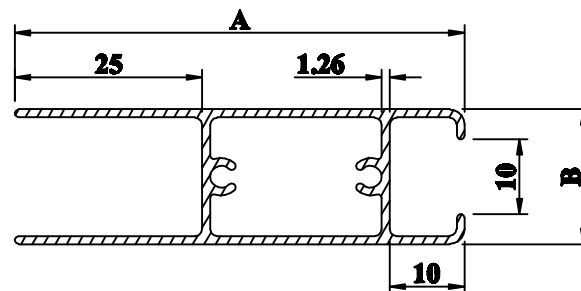

Sr. no.	Section No.	A	B	T	Wt. Rang /12'
1	1270	60.0	18.0	1.01	1.750 To 1.900 Kg

WARDHAN EXTRUSION

Rectangle Tube

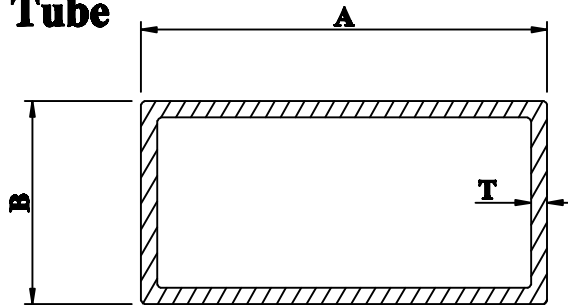

Sr. no.	Section No.	A	B	T	Wt. Rang /12'
1	1280	38.0	25.0	0.84	1.000 To 1.100 Kg
2	1281	50.0	25.0	0.68	1.000 To 1.100 Kg
3	1282	50.0	25.0	0.91	1.300 To 1.400 Kg
4	1283	63.0	38.0	0.74	1.450 To 1.550 Kg
5	1284	63.0	38.0	0.95	1.850 To 1.950 Kg
6	1285	63.0	38.0	1.32	2.550 To 2.650 Kg
7	1286	75.0	25.0	1.57	3.000 To 3.150 Kg
8	1287	100.0	25.0	0.98	3.000 To 3.150 Kg
9	1288	75.0	25.0	2.06	3.930 To 4.130 Kg
10	1289	100.0	25.0	1.18	3.600 To 3.800 Kg
11	1290	101.0	44.0	1.30	3.600 To 3.800 Kg

Square Tube

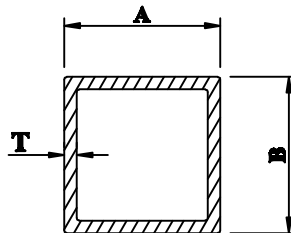

Sr. no.	Section No.	A	B	T	Wt. Rang /12'
1	1290	25.0	25.0	0.85	0.800 To 0.950 Kg
2	1291	50.0	50.0	1.38	2.650 To 2.800 Kg
3	1292	25.0	25.0	1.25	1.040 To 1.240 Kg
4	1293	25.0	25.0	4.00	3.300 To 3.500 Kg
5	1294	50.0	50.0	2.00	3.750 To 2.950 Kg

WARDHAN EXTRUSION

2 Track Top

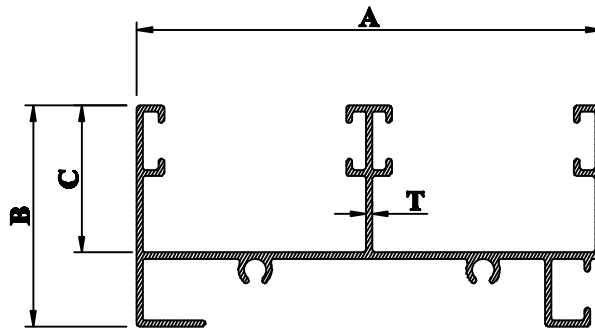

Sr. no.	Section No.	A	B	C	T	Wt. Rang /12'
1	1300	62.0	29.5	19.6	0.68	1.450 To 1.550 Kg
2	1301	62.0	29.5	19.6	0.95	1.950 To 2.150 Kg
3	1302	62.0	29.5	19.6	1.28	2.600 To 2.800 Kg

2 Track Bottom

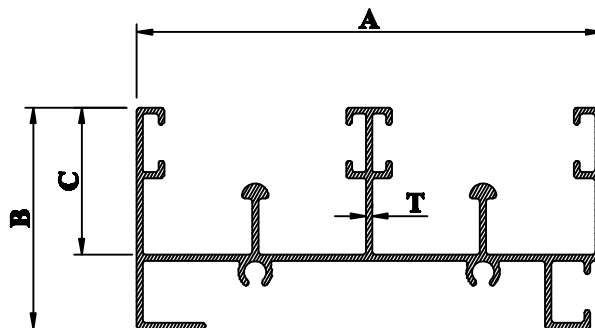

Sr. no.	Section No.	A	B	C	T	Wt. Rang /12'
1	1310	62.0	29.5	19.6	0.68	1.700 To 1.850 Kg
2	1311	62.0	29.5	19.6	1.10	2.350 To 2.500 Kg

WARDHAN EXTRUSION

3 Track Top

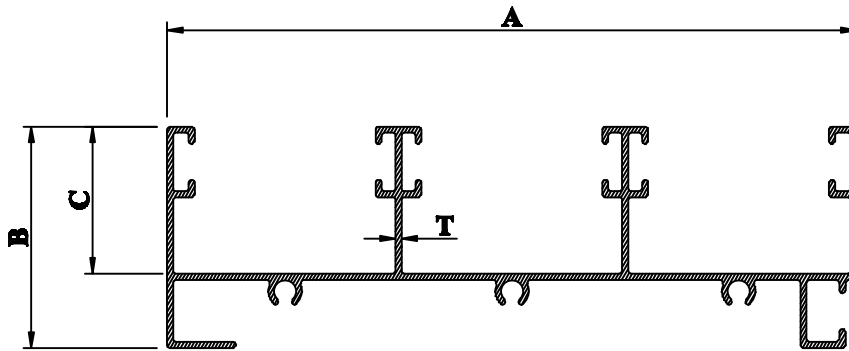

Sr. no.	Section No.	A	B	C	T	Wt. Rang /12'
1	1320	92.0	29.5	19.6	0.92	2.650 To 2.850 Kg

3 Track Bottom

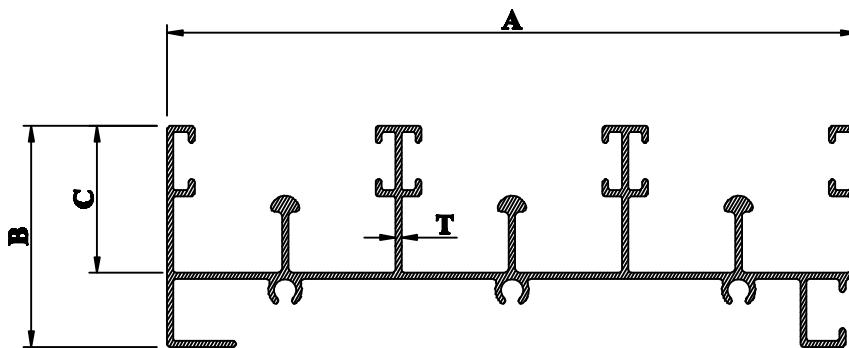

Sr. no.	Section No.	A	B	C	T	Wt. Rang /12'
1	1330	92.0	29.5	19.6	0.76	2.550 To 2.750 Kg
2	1331	92.0	29.5	19.6	0.64	2.100 To 2.300 Kg
3	1332	92.0	29.5	19.6	0.81	2.700 To 2.900 Kg

WARDHAN EXTRUSION

Flat Bar

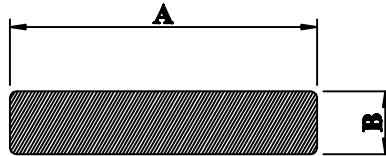

Sr. no.	Section No.	A	B	Wt. Rang /12'
1	1360	25.0	3.00	0.700 To 0.850 Kg
2	1361	100.0	12.00	11.85 To 13.85 Kg

Plan "T"

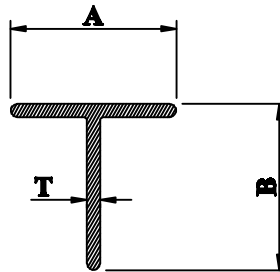

Sr. no.	Section No.	A	B	T	Wt. Rang /12'
1	1370	19.0	19.0	0.82	0.300 To 0.400 Kg
2	1371	25.0	25.0	1.08	0.500 To 0.600 Kg

D.G.C

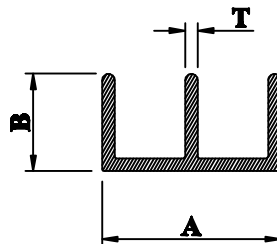

Sr. no.	Section No.	A	B	T	Wt. Rang /12'
1	1380	22.0	12.0	0.75	0.400 To 0.500 Kg
2	1381	22.0	12.0	0.95	0.500 To 0.600 Kg

WARDHAN EXTRUSION

Curtain Wall

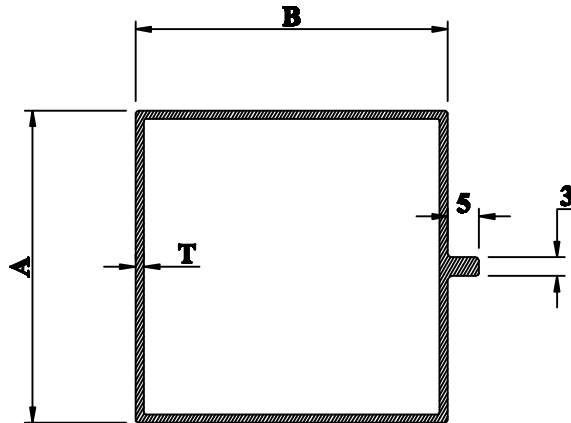

Sr. no.	Section No.	A	B	T	Wt. Rang /12'
1	1340	44.0	47.0	0.94	1.800 To 1.900 Kg
2	1341	44.0	47.0	1.05	2.000 To 2.100 Kg
3	1342	44.0	47.0	1.18	2.200 To 2.300 Kg
4	1343	50.0	50.0	0.96	2.000 To 2.100 Kg
5	1344	50.0	50.0	1.08	2.200 To 2.300 Kg
6	1345	50.0	50.0	1.12	2.300 To 2.400 Kg
7	1346	50.0	50.0	1.49	3.000 To 3.150 Kg

Angle

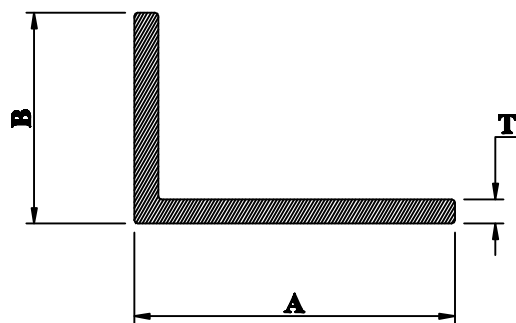

Sr. no.	Section No.	A	B	T	Wt. Rang /12'
1	1350	38.0	25.0	2.20	1.300 To 1.500 Kg
2	1351	38.0	25.0	3.06	1.800 To 2.000 Kg
2	1351	25.0	20.0	4.80	1.900 To 2.100 Kg

WARDHAN EXTRUSION

Molding Handle

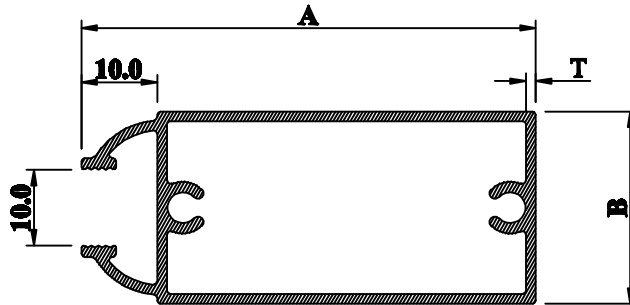

Sr. no.	Section No.	A	B	T	Wt. Rang /12'
1	1390	60.0	25.0	0.89	1.800 To 1.900 Kg
2	1391	60.0	25.0	1.09	2.100 To 2.200 Kg
3	1392	80.0	25.0	0.78	1.900 To 2.000 Kg
4	1393	80.0	25.0	0.86	2.100 To 2.200 Kg
5	1394	80.0	25.0	0.98	2.300 To 2.400 Kg
6	1395	80.0	25.0	1.30	3.000 To 3.150 Kg

Molding Middle

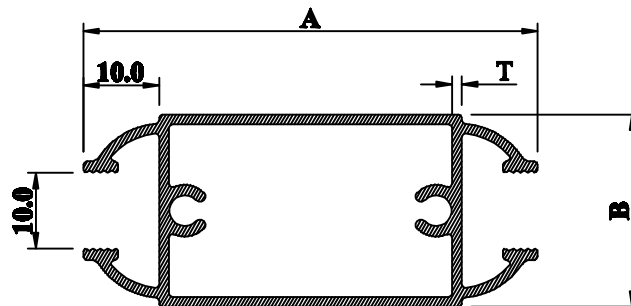

Sr. no.	Section No.	A	B	T	Wt. Rang /12'
1	1400	60.0	25.0	0.87	1.800 To 1.900 Kg
2	1401	60.0	25.0	1.03	2.100 To 2.200 Kg
3	1402	80.0	25.0	0.78	2.000 To 2.100 Kg
4	1403	80.0	25.0	0.89	2.200 To 2.400 Kg
5	1404	80.0	25.0	0.95	2.300 To 2.400 Kg
6	1405	80.0	25.0	1.24	3.000 To 3.150 Kg

WARDHAN EXTRUSION

Molding Single Leg

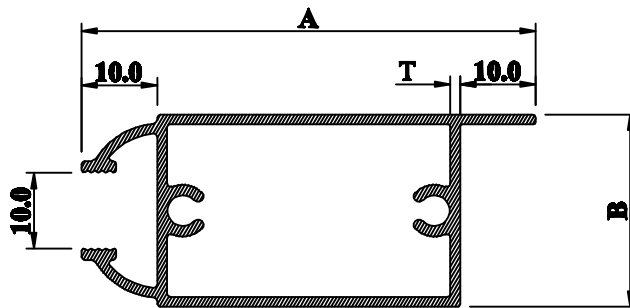

Sr. no.	Section No.	A	B	T	Wt. Rang /12'
1	1410	60.0	25.0	0.96	1.800 To 1.900 Kg
2	1411	60.0	25.0	1.14	2.100 To 2.200 Kg
3	1412	80.0	25.0	0.88	2.000 To 2.100 Kg

Molding Top Bottom

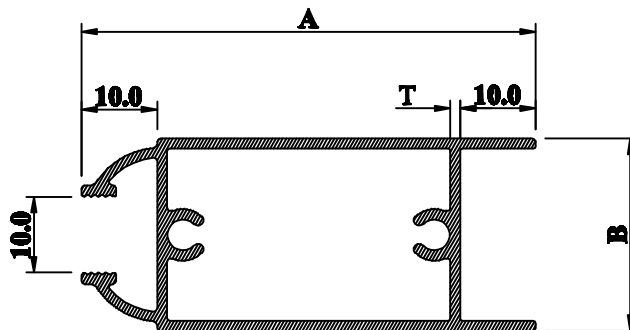

Sr. no.	Section No.	A	B	T	Wt. Rang /12'
1	1420	60.0	25.0	0.88	1.700 To 1.800 Kg
2	1421	80.0	25.0	0.88	2.100 To 2.200 Kg
3	1422	80.0	25.0	1.29	3.000 To 3.100 Kg
4	1423	80.0	25.0	1.21	2.800 To 2.900 Kg
5	1424	80.0	25.0	1.74	4.030 To 4.130 Kg

WARDHAN EXTRUSION

Plan Handle

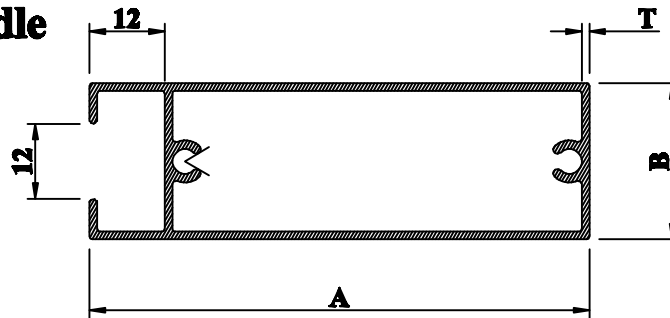

Sr. no.	Section No.	A	B	T	Wt. Rang /12'
1	1430	80.0	25.0	0.89	2.100 To 2.200 Kg

Plan Top Bottom

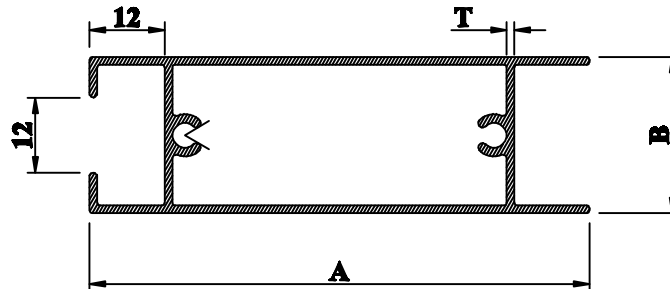

Sr. no.	Section No.	A	B	T	Wt. Rang /12'
1	1440	80.0	25.0	0.89	2.100 To 2.200 Kg

Plan Middle

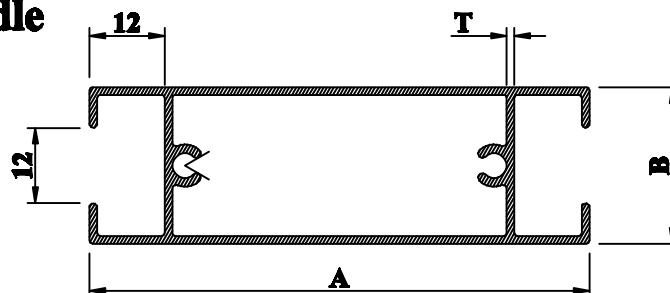

Sr. no.	Section No.	A	B	T	Wt. Rang /12'
1	1450	80.0	25.0	0.86	2.100 To 2.200 Kg

WARDHAN EXTRUSION

"L" Pipe

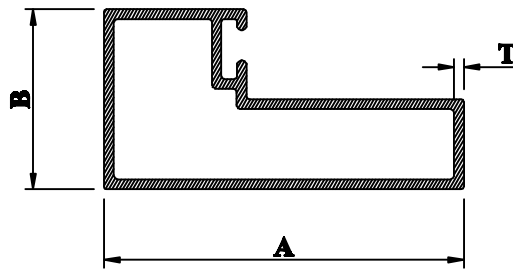

Sr. no.	Section No.	A	B	T	Wt. Rang /12'
1	1460	50.0	25.0	0.90	1.300 To 1.400 Kg
2	1460	50.0	25.0	0.96	1.400 To 1.500 Kg

"L" Pipe

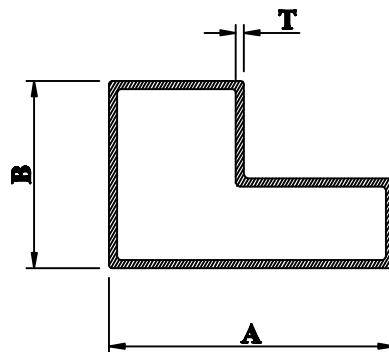

Sr. no.	Section No.	A	B	T	Wt. Rang /12'
1	1470	38.0	25.0	0.92	1.100 To 1.200 Kg
2	1471	38.0	25.0	1.04	1.200 To 1.300 Kg
3	1472	38.0	25.0	1.22	1.400 To 1.500 Kg

WARDHAN EXTRUSION

"L" Pipe

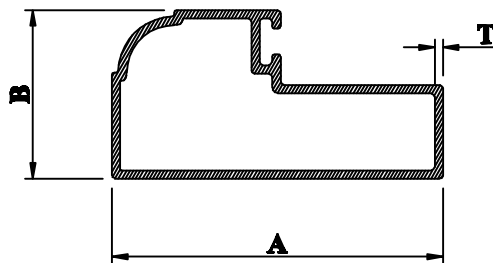

Sr. no.	Section No.	A	B	T	Wt. Rang /12'
1	1480	54.0	27.0	0.92	1.450 To 1.550 Kg
2	1481	54.0	27.0	1.40	2.200 To 2.300 Kg
3	1482	54.0	27.0	1.16	1.800 To 2.000 Kg

"L" Pipe

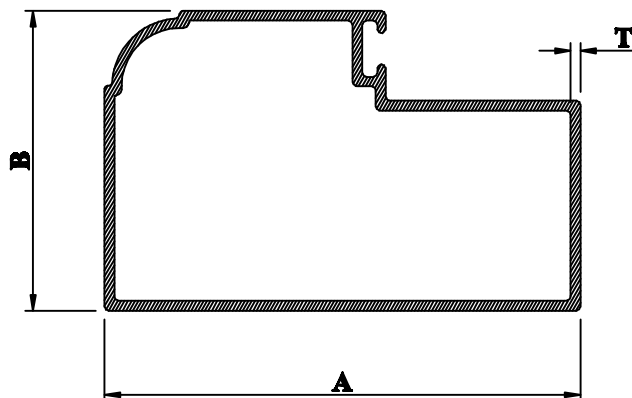

Sr. no.	Section No.	A	B	T	Wt. Rang /12'
1	1490	64.0	40.0	0.88	1.800 To 1.900 Kg
2	1491	64.0	40.0	1.05	2.100 To 2.200 Kg
3	1492	64.0	40.0	1.18	2.400 To 2.500 Kg
4	1493	64.0	40.0	1.14	2.300 To 2.400 Kg

WARDHAN EXTRUSION

Dommal 3 Track

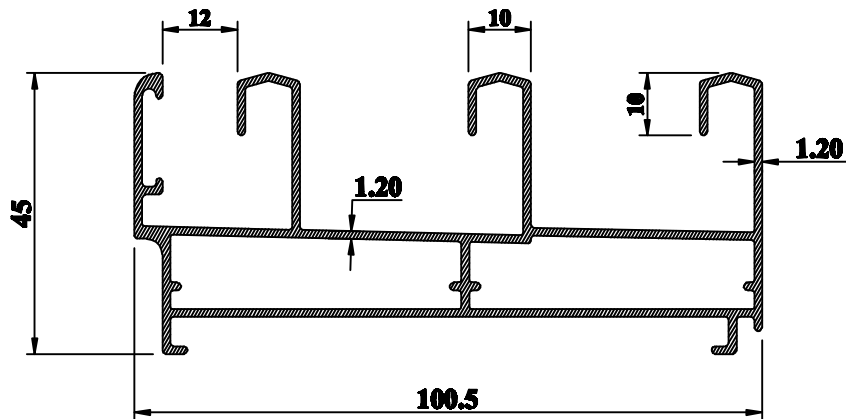

WEIGHT:- 5.000 kg/12'

Dommal 3 Track

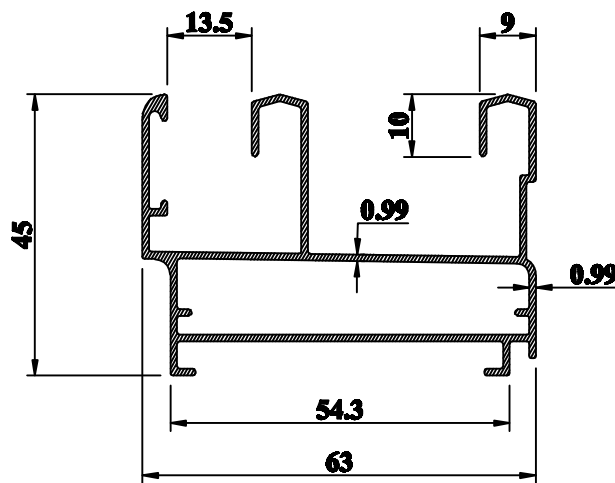

WEIGHT:- 2.900 kg/12'

WARDHAN EXTRUSION

Dommal Shutter

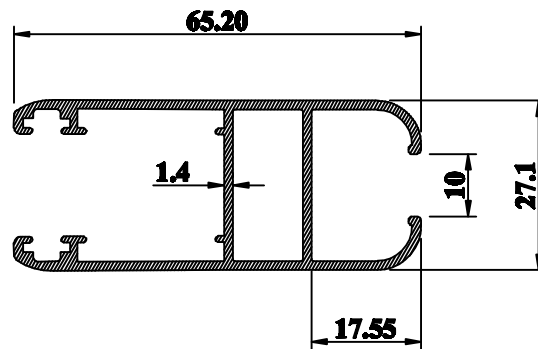

WEIGHT:- 3.000 kg/12'

WARDHAN EXTRUSION

20mm Interlock

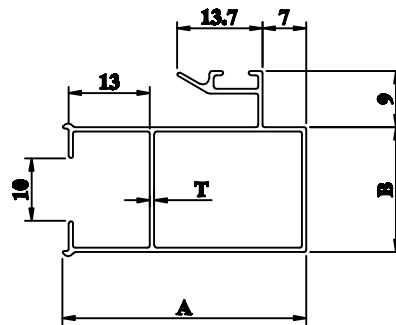

Sr. no.	Section No.	A	B	T	Wt. Rang /12'
1	1500	39.0	20.0	1.25	1.900 To 2.100 Kg

20mm Handle

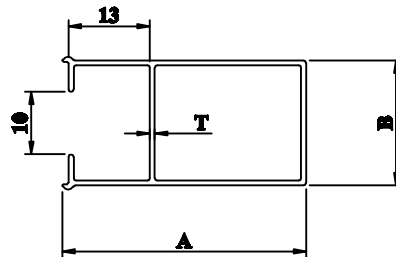

Sr. no.	Section No.	A	B	T	Wt. Rang /12'
1	1600	39.0	20.0	1.14	1.400 To 1.600 Kg
2	1601	39.0	20.0	1.30	1.600 To 1.800 Kg

WARDHAN EXTRUSION

S L DOOR TOP

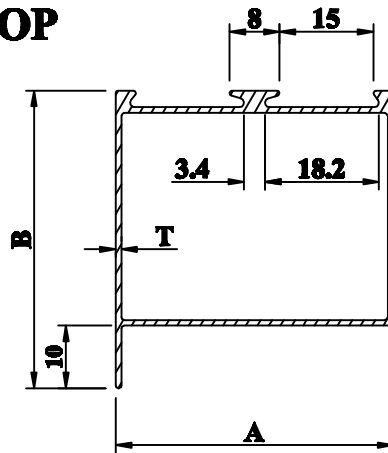

Sr. no.	Section No.	A	B	T	Wt. Rang /12'
1	1700	44.45	47.50	1.29	2.490 To 2.690 Kg

WARDHAN EXTRUSION

Angle

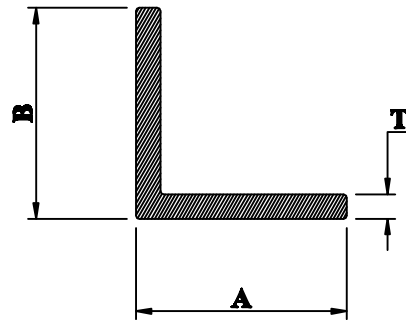

Sr. no.	Section No.	A	B	T	Wt. Rang /12'
1	1800	25.0	25.0	2.46	1.150 To 1.350Kg
2	1801	25.0	25.0	2.46	1.150 To 1.350Kg
3	1802	25.0	25.0	3.15	1.450 To 1.650Kg
4	1803	50.0	50.0	4.46	4.200 To 4.400Kg

WARDHAN EXTRUSION

Flat Bar

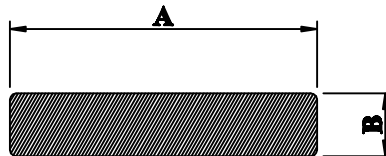

Sr. no.	Section No.	A	B	Wt. Rang /12'
1	1360	25.0	3.00	0.700 To 0.850 Kg
2	1361	100.0	12.00	11.85 To 13.85 Kg
3	1362	28.0	14.50	4.00 To 4.200 Kg

Plan "T"

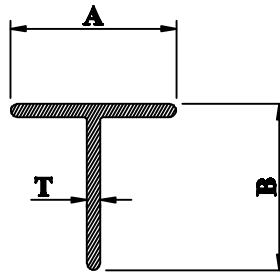

Sr. no.	Section No.	A	B	T	Wt. Rang /12'
1	1370	19.0	19.0	0.82	0.300 To 0.400 Kg
2	1371	25.0	25.0	1.08	0.500 To 0.600 Kg

D.G.C

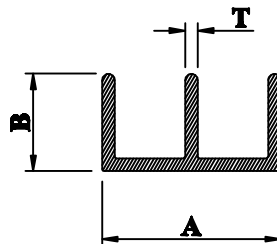

Sr. no.	Section No.	A	B	T	Wt. Rang /12'
1	1380	22.0	12.0	0.75	0.400 To 0.500 Kg
2	1381	22.0	12.0	0.95	0.500 To 0.600 Kg

WARDHAN EXTRUSION

Angle

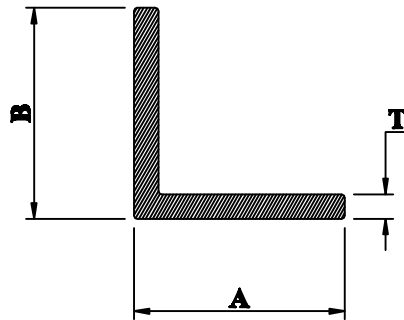

Sr. no.	Section No.	A	B	T	Wt. Rang /12'
1	1800	25.0	25.0	2.46	1.150 To 1.350Kg
2	1801	25.0	25.0	2.46	1.150 To 1.350Kg
3	1802	25.0	25.0	3.15	1.450 To 1.650Kg
4	1803	50.0	50.0	4.46	4.200 To 4.400Kg

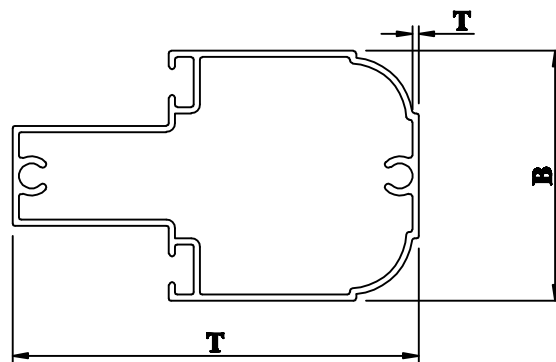

Sr. no.	Section No.	A	B	T	Wt. Rang /12'
1	1900	65.00	40.0	1.00	2.300 To 2.500Kg
2					
3					
4					

WARDHAN EXTRUSION

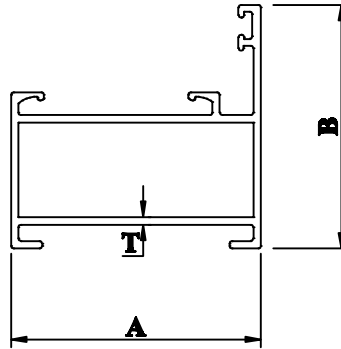

Sr. no.	Section No.	A	B	T	Wt. Rang /12'
1	1900	40.0	39.0	1.20	1.900 To 2.100Kg
2					
3					
4					

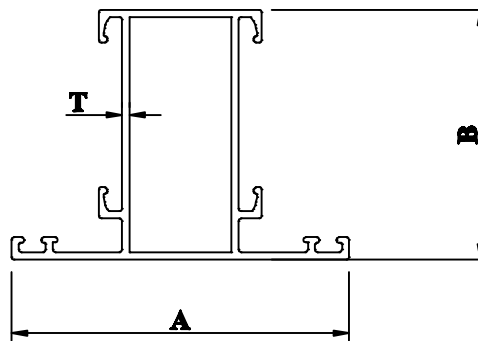

Sr. no.	Section No.	A	B	T	Wt. Rang /12'
1	1950	54.0	40.0	1.20	2.250 To 2.450Kg
2					
3					
4					

WARDHAN EXTRUSION

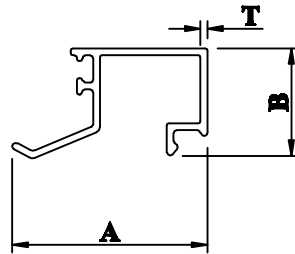

Sr. no.	Section No.	A	B	T	Wt. Rang /12'
1	2000	31.20	17.20	1.10	0.800 To 1.00Kg
2					
3					
4					

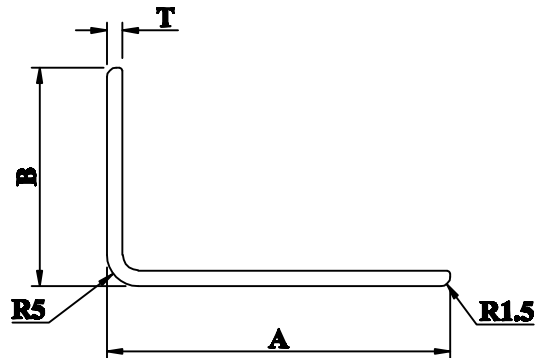

Sr. no.	Section No.	A	B	T	Wt. Rang /12'
1	2050	55.0	35.0	2.50	2.100 To 2.300Kg
2					
3					
4					

WARDHAN EXTRUSION

ANGLE

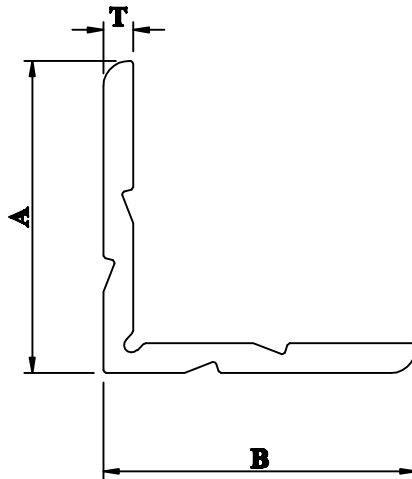

Sr. no.	Section No.	A	B	T	Wt. Rang /12'
1	2100	50.00	50.00	4.80	4.200 To 4.400Kg
2					
3					
4					

G CHANNLE

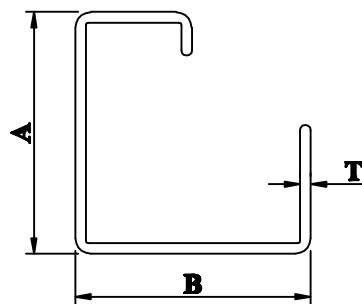

Sr. no.	Section No.	A	B	T	Wt. Rang /12'
1	2150	38.70	37.70	1.70	1.880 To 2.080Kg
2					
3					
4					

WARDHAN EXTRUSION

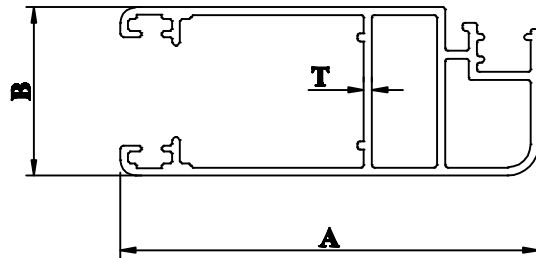

Sr. no.	Section No.	A	B	T	Wt. Rang /12'
1	2200	67.00	27.00	1.30	3.100 To 3.300Kg
2					
3					
4					

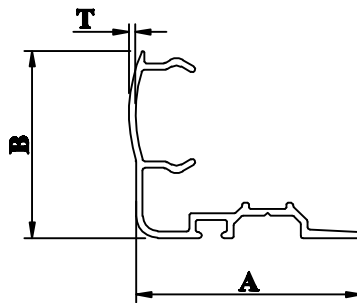

Sr. no.	Section No.	A	B	T	Wt. Rang /12'
1	2250	36.10	30.00	1.02	1.00 To 1.200Kg
2					
3					
4					

WARDHAN EXTRUSION

INTERLOCK

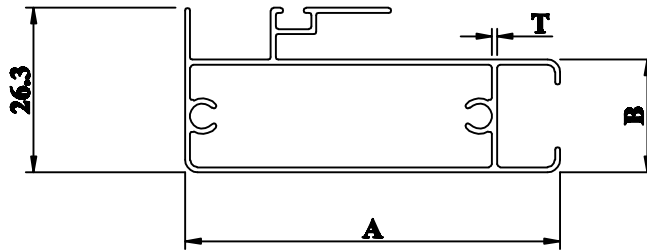

Sr. no.	Section No.	A	B	T	Wt. Rang /12'
1	2300	60.00	18.00	0.78	1.700 To 1.900Kg
2					
3					
4					

HANDLE

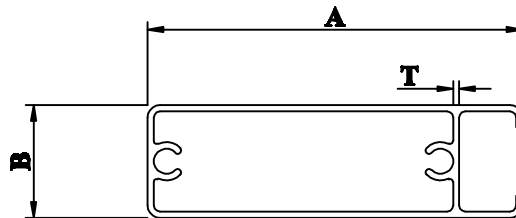

Sr. no.	Section No.	A	B	T	Wt. Rang /12'
1	2350	60.00	18.00	0.97	1.700 To 1.900Kg
2					
3					
4					

WARDHAN EXTRUSION

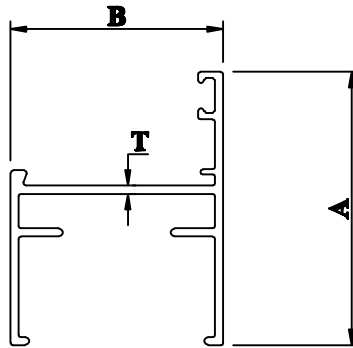

Sr. no.	Section No.	A	B	T	Wt. Rang /12'
1	2400	43.75	34.00	1.40	1.650 To 1.850Kg
2					
3					
4					

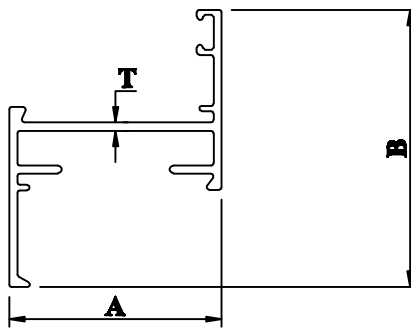

Sr. no.	Section No.	A	B	T	Wt. Rang /12'
1	2450	34.00	44.35	1.35	1.490 To 1.690Kg
2					
3					
4					

WARDHAN EXTRUSION

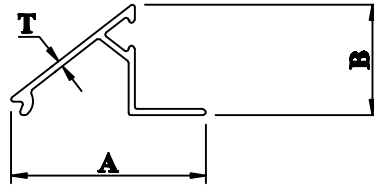

Sr. no.	Section No.	A	B	T	Wt. Rang /12'
1	2500	31.20	17.7	1.00	0.600 To 0.800Kg
2					
3					
4					

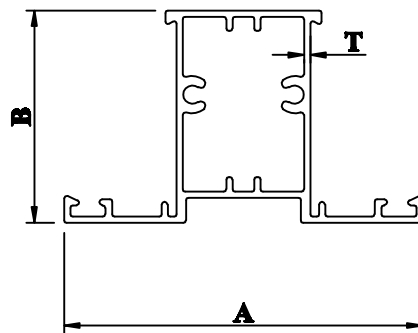

Sr. no.	Section No.	A	B	T	Wt. Rang /12'
1	2550	57.40	34.00	1.00	2.00 To 2.200Kg
2					
3					
4					

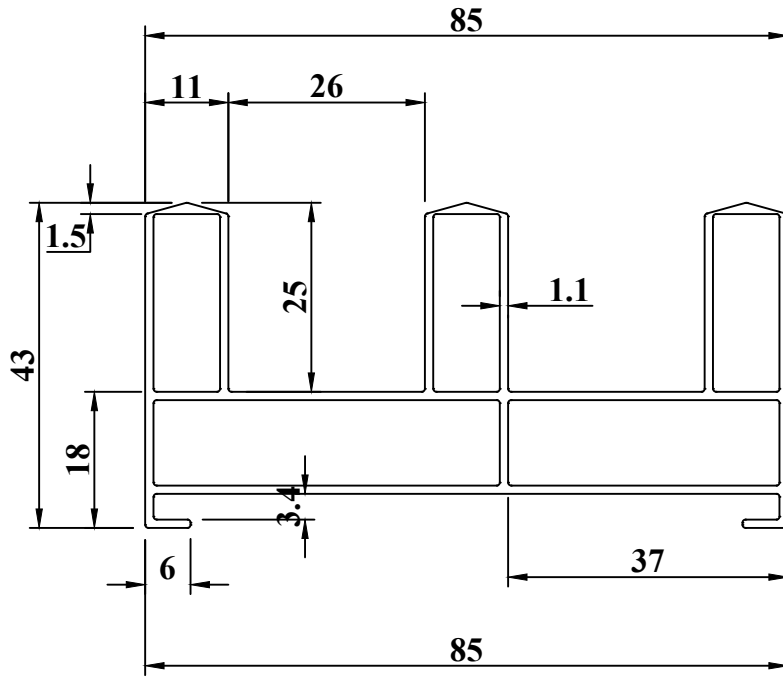

NOTE:- UNSPECIFIED RADIUS 0.40R
 :- ALL DIMENSIONS ARE IN mm.
 :- TWIST & STRAIGHTNESS/Mtr - 1.70 mm
 :- FLATNESS/Mtr - 0.007XWIDTH
 :- UNSPECIFIED TOLERANCE ± 0.20

WARDHAN EXTRUSION

AREA:- 425.71 Sqmm [^]		DRAWN BY:-
WEIGHT:- 4.20 kg/12'		CHECKED BY:-
TYPE:- HOLLOW	TEMPER :- T6	APPROVED BY:-
PARTY NAME.:-		SCALE:- 1:1
		DRG.NO :-2023:29:09:002

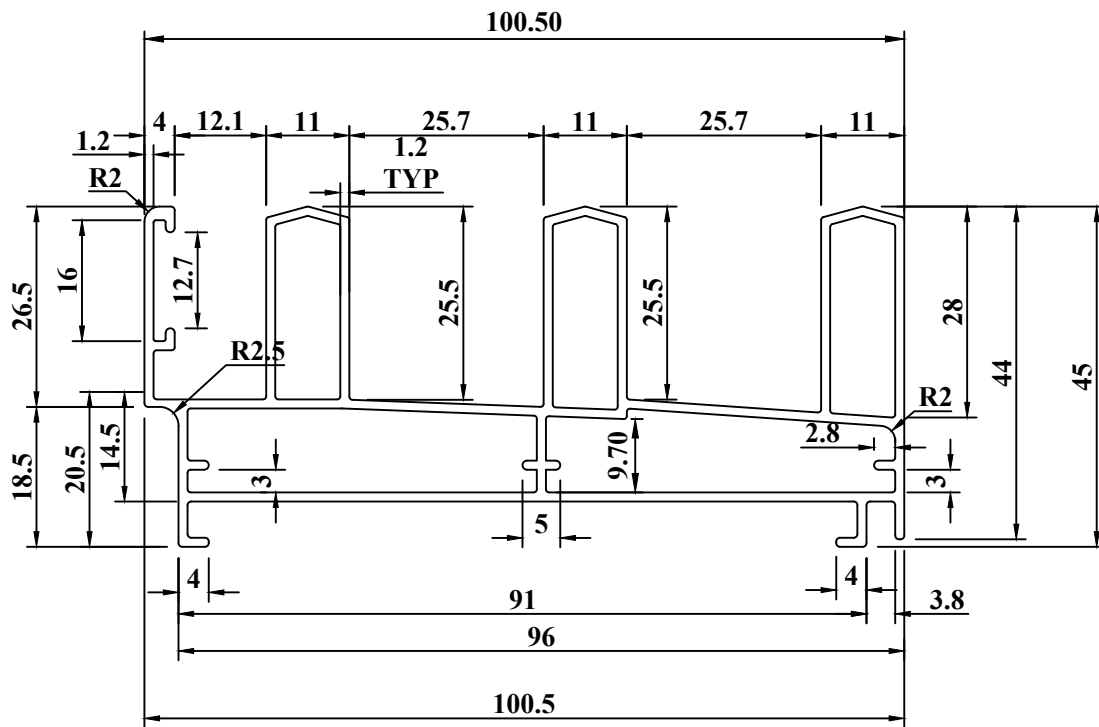

- NOTE:- UNSPECIFIED RADIUS 0.40R
 :- ALL DIMENSIONS ARE IN mm.
 :- TWIST & STRAIGHTNESS/Mtr - 1.70 mm
 :- FLATNESS/Mtr - 0.007XWIDTH
 :- UNSPECIFIED TOLERANCE ± 0.20

WARDHAN EXTRUSION

AREA:- 567.45 Sqmm [^]		DRAWN BY:-
WEIGHT:- 5.594 kg/12'		CHECKED BY:-
TYPE:- HOLLOW	TEMPER :- T6	APPROVED BY:-
PARTY NAME.:-		SCALE:- 1:1
		DRG.NO :-2023:29:09:003

PRODUCED BY AN AUTODESK EDUCATIONAL PRODUCT

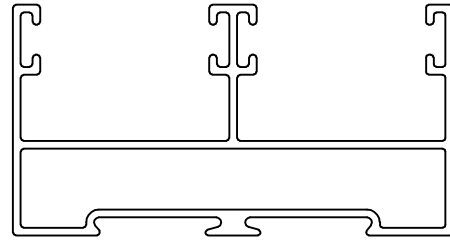

SCALE:- 1:1

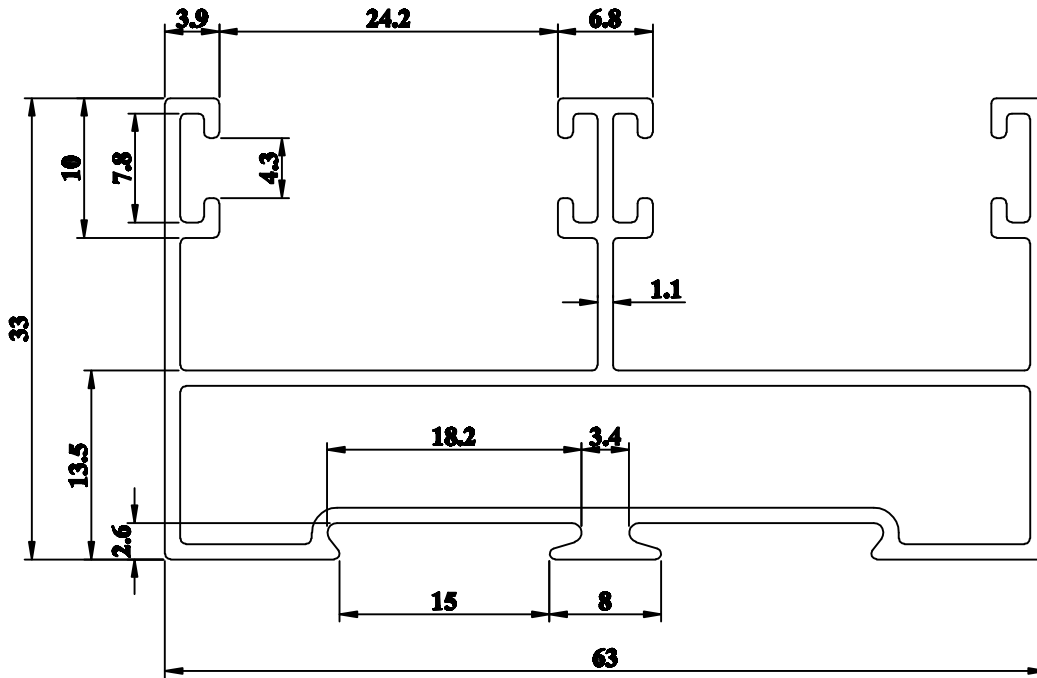

NOTE:- UNSPECIFIED RADIUS 0.4R
 :- ALL DIMENSIONS ARE IN mm.
 :- TWIST & STRAIGHTNESS-
 :- FLATNESS -

WARDHAN EXTRUSION

AREA:- 288.41 Sqmm [^]		DRAWN BY:-
WEIGHT:- 2.850 kg/12'	ALLOY :-	CHECKED BY:-
TYPE:- HOLLOW	TEMPER :-	APPROVED BY:-
		SCALE:- 2:1
PARTY NAME.:-		DRG.NO :-01042023-1

PRODUCED BY AN AUTODESK EDUCATIONAL PRODUCT

PRODUCED BY AN AUTODESK EDUCATIONAL PRODUCT

PRODUCED BY AN AUTODESK EDUCATIONAL PRODUCT

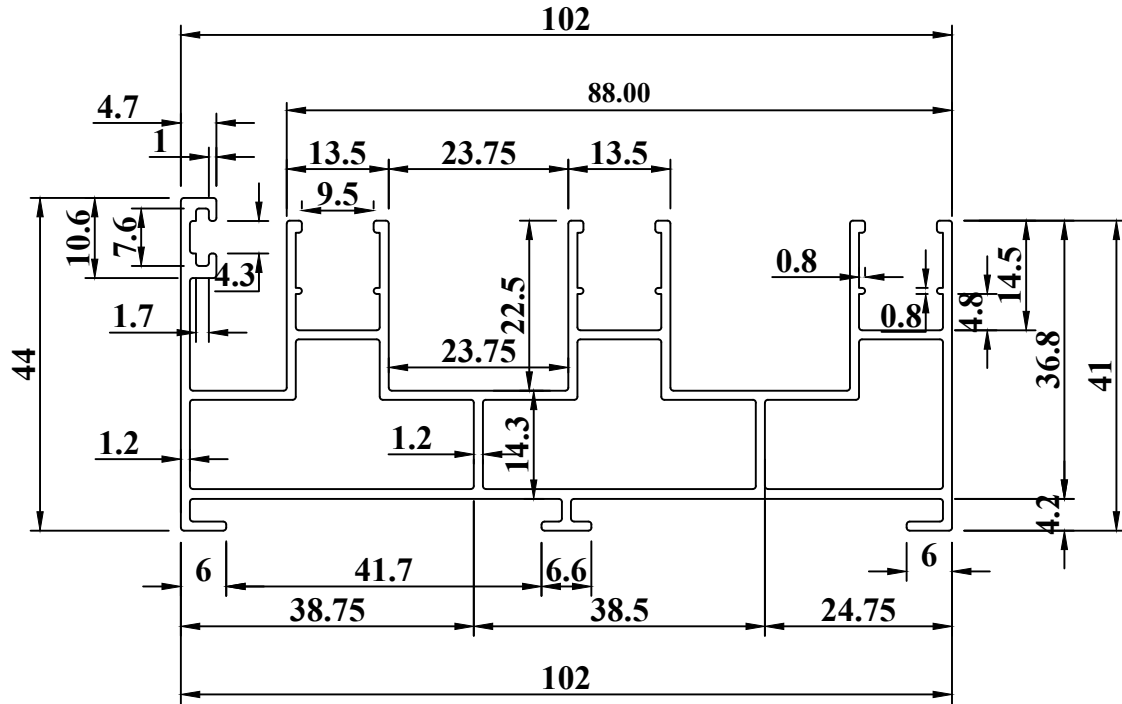

- NOTE:- UNSPECIFIED RADIUS 0.40R
 :- ALL DIMENSIONS ARE IN mm.
 :- TWIST & STRAIGHTNESS/Mtr - 1.70 mm
 :- FLATNESS/Mtr - 0.007XWIDTH
 :- UNSPECIFIED TOLERANCE ± 0.20

WARDHAN EXTRUSION

AREA:- 565.03 Sqmm [^]		DRAWN BY:-
WEIGHT:- 5.583 kg/12'		CHECKED BY:-
TYPE:- HOLLOW	TEMPER :- T6	APPROVED BY:-
PARTY NAME.:-		SCALE:- 1:1
		DRG.NO :-2023:29:09:000

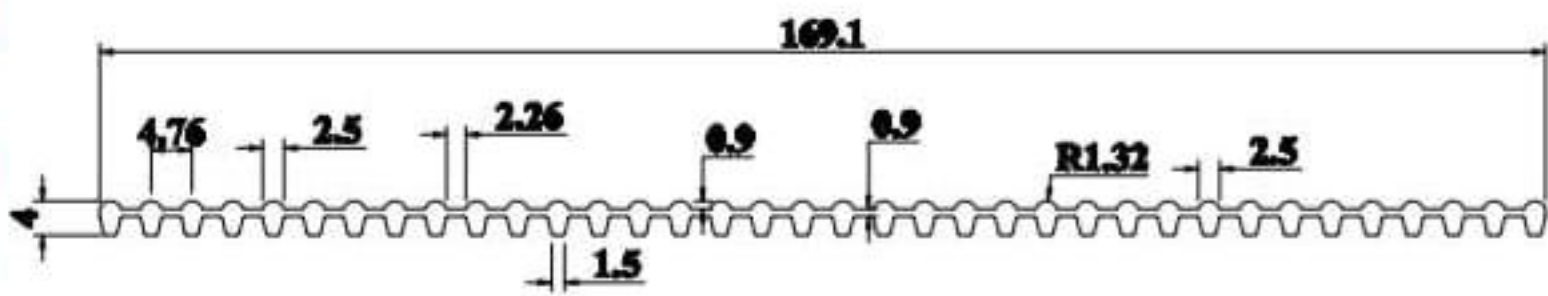

- NOTE:- UNSPECIFIED RADIUS 0.25R
 :- ALL DIMENSIONS ARE IN mm.
 :- TWIST & STRAIGHTNESS/Mtr - 1.70 mm
 :- FLATNESS/Mtr - 0.007XWIDTH
 :- UNSPECIFIED TOLERANCE ±0.20

WARDHAN EXTRUSION

AREA:- 369.79 Sqmm [^]		DRAWN BY:-
WEIGHT:- 3.654 kg/12'		CHECKED BY:-
TYPE:- SOLID	TEMPER :- T6	APPROVED BY:-
		SCALE:- 1:1
PARTY NAME.:-		DRG.NO :-36 BULB GRILL

PRODUCED BY AN AUTODESK EDUCATIONAL PRODUCT

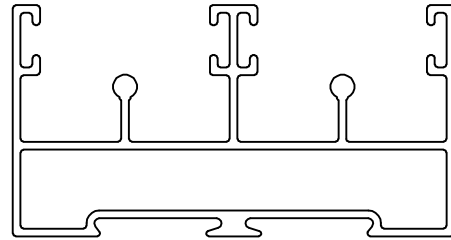

SCALE:- 1:1

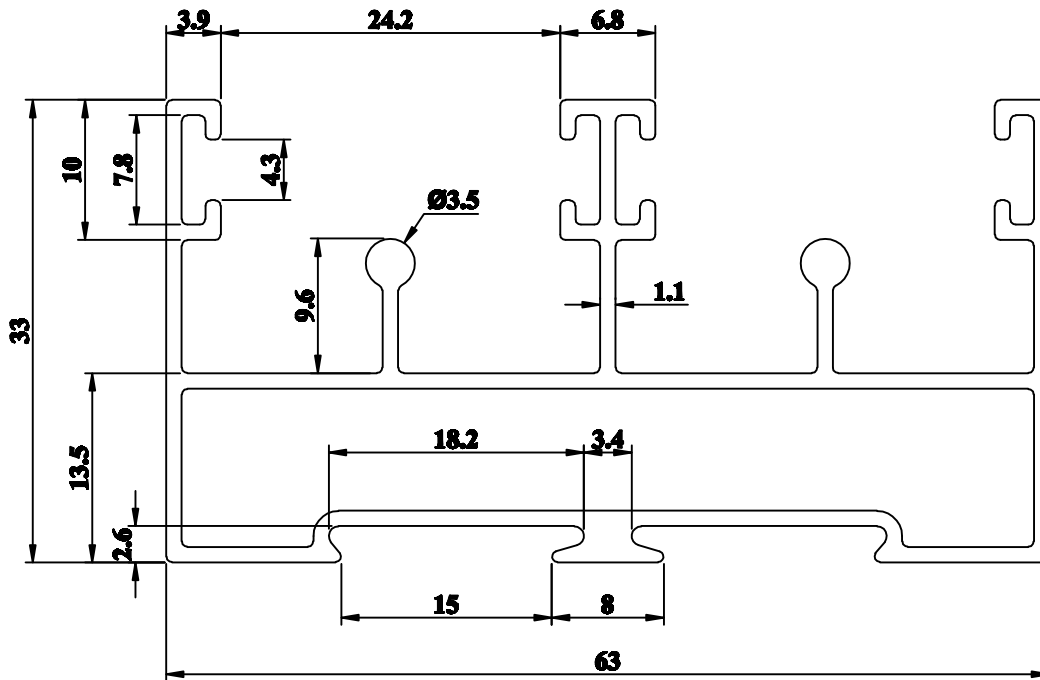

NOTE:- UNSPECIFIED RADIUS 0.4R
 :- ALL DIMENSIONS ARE IN mm.
 :- TWIST & STRAIGHTNESS-
 :- FLATNESS -

WARDHAN EXTRUSION

AREA:- 321.33 Sqmm [^]		DRAWN BY:-
WEIGHT:- 3.175 kg/12'	ALLOY :-	CHECKED BY:-
TYPE:- HOLLOW	TEMPER :-	APPROVED BY:-
PARTY NAME.:-		SCALE:- 2:1
		DRG.NO :-01042023-2

PRODUCED BY AN AUTODESK EDUCATIONAL PRODUCT

PRODUCED BY AN AUTODESK EDUCATIONAL PRODUCT

PRODUCED BY AN AUTODESK EDUCATIONAL PRODUCT

PRODUCED BY AN AUTODESK EDUCATIONAL PRODUCT

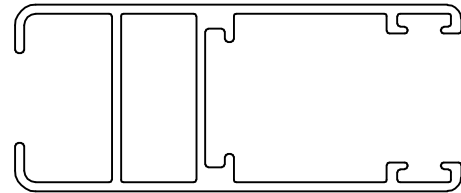

SCALE:- 1:1

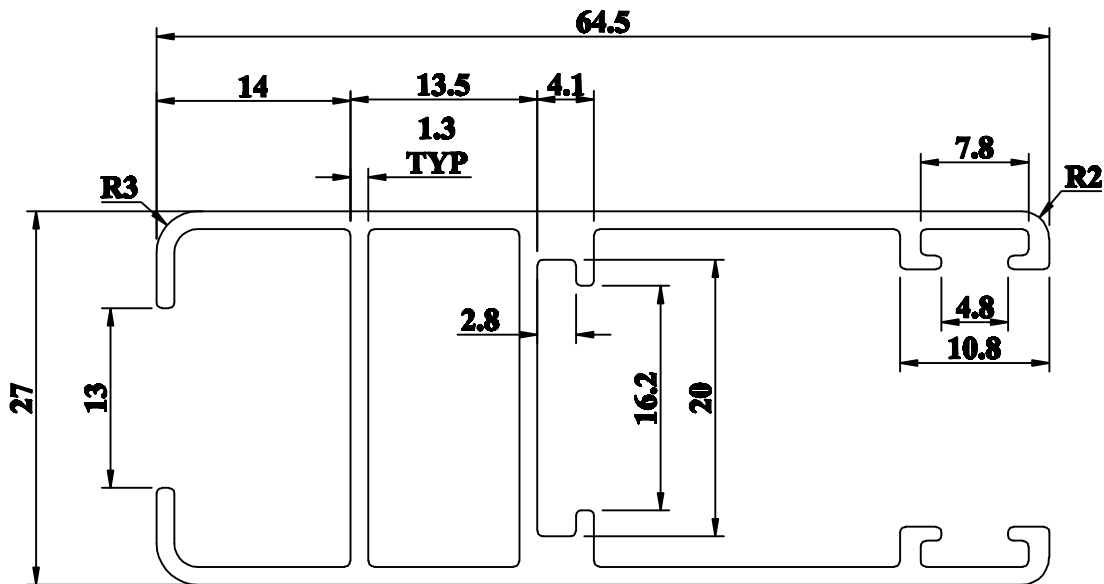

- NOTE:- UNSPECIFIED RADIUS 0.35R
 :- ALL DIMENSIONS ARE IN mm.
 :- TWIST & STRAIGHTNESS/Mtr - 1.70 mm
 :- FLATNESS/Mtr - 0.007XWIDTH
 :- UNSPECIFIED TOLERANCE ± 0.20

WARDHAN EXTRUSION

AREA:- 288.06 Sqmm [^]		DRAWN BY:-
WEIGHT:- 2.846 kg/12'		CHECKED BY:-
TYPE:- HOLLOW	TEMPER :- T6	APPROVED BY:-
PARTY NAME.:-		SCALE:- 2:1
		DRG.NO :-0004

PRODUCED BY AN AUTODESK EDUCATIONAL PRODUCT

PRODUCED BY AN AUTODESK EDUCATIONAL PRODUCT

PRODUCED BY AN AUTODESK EDUCATIONAL PRODUCT

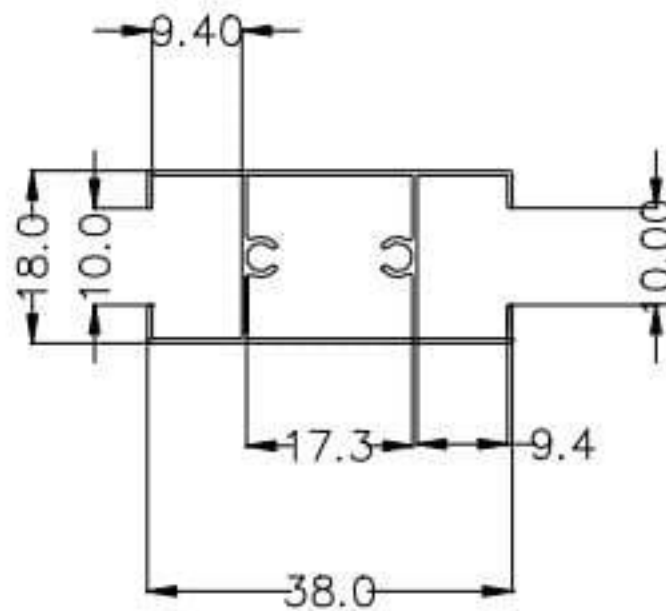

Wall thickness 0.50 mm

Twist: $1/4$ / 300 mm / meter

Straightness: 1.5 mm / meter

Angularity : 0 2

All dimensions are in M.M.

Unspecified Corner Radius 0.25 m.m.

Wardhan Extrusion Sikar Raj.

Party sample/Drg.		Party Name		18 mm Handle Middle	
				Drawn	Area 71.0 mm ²
				Checked	Weight 0.192 Kg/m
				Approved	30.8.23 Wt.Range 0.900-1.100 Kg/16
				Scale: 1:1	Date Alloy & Tempe#E 9
				Critical Dim. *	Apex Drg.No.
Revision Status	Rev. No.	Description	Sign. Date	Perimeter	Int. -
REVISION					Sec. No.

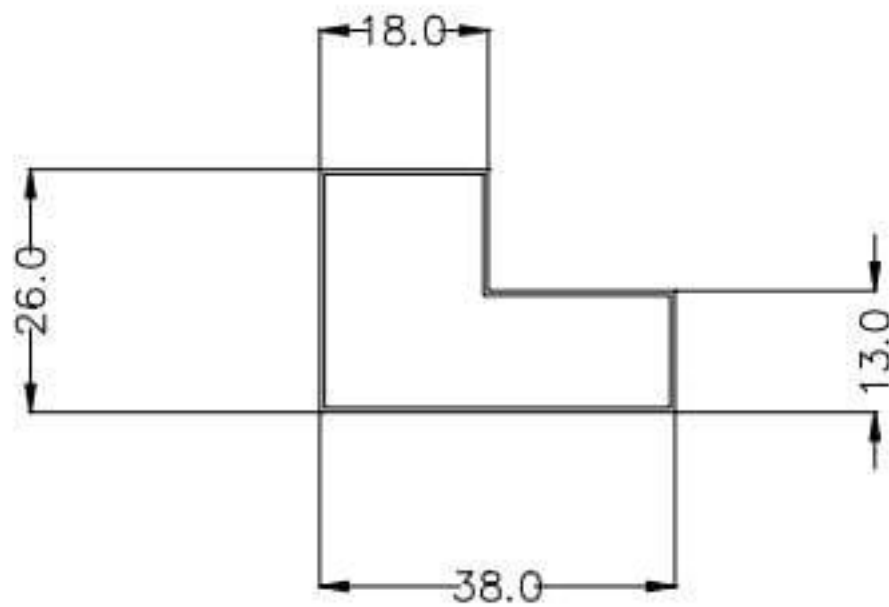

Wall thickness 0.55 mm

Twist: 194 / 300 mm / meter

Straightness: 1.5 mm / meter

Angularity : 0 2

All dimensions are in M.M.

Unspecified Corner Radius 0.25 m.m.

Wardhan Extrusion Sikar Raj.

Party sample/Drg.		Party Name		P Pipe	
				Drawn	Area 73 mm ²
				Checked	Weight 0.197 Kg/m
				Approved	30.8.23 Wt.Range 0.900-1.100 Kg/15'
				Scale: 1:1	Date Alloy & TempeHE 9
				Critical Dim. *	Apex Drg.No.
Revision Status	Rev. No.	Description	Sign. Date	Perimeter	Int. -
REVISION					Sec. No.

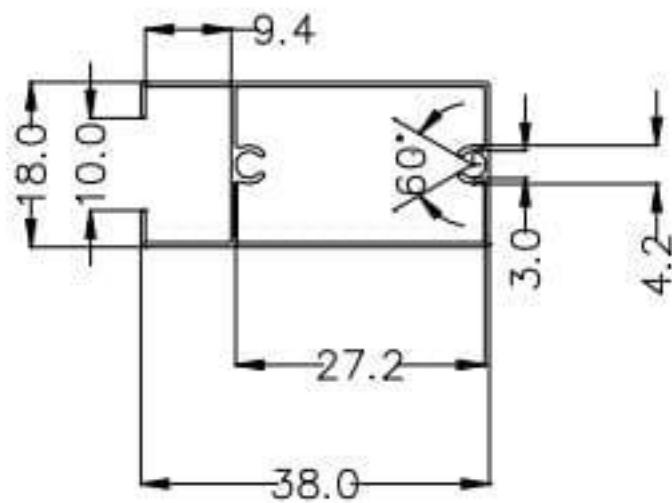

Wall thickness 0.55 mm

Twist: $1\frac{9}{4}$ / 300 mm / meter

Straightness: 1.5 mm / meter

Angularity : $^{\circ}$ 2

All dimensions are in M.M.

Unspecified Corner Radius 0.25 m.m.

Wardhan Extrusion Sikar Raj.

Party sample/Drg.		Party Name		18 mm Top Bottom	
				Drawn	Area 74 mm ²
				Checked	Weight 0.200 Kg/m
				Approved	30.8.23 Wt.Range 0.900-1.100 Kg/16
				Scale: 1:1	Date Alloy & TempeHE 9
				Critical Dim. *	Apex Drg.No.
Revision Status	Rev. No.	Description	Sign. Date	Perimeter	Int. -
REVISION					Sec. No.

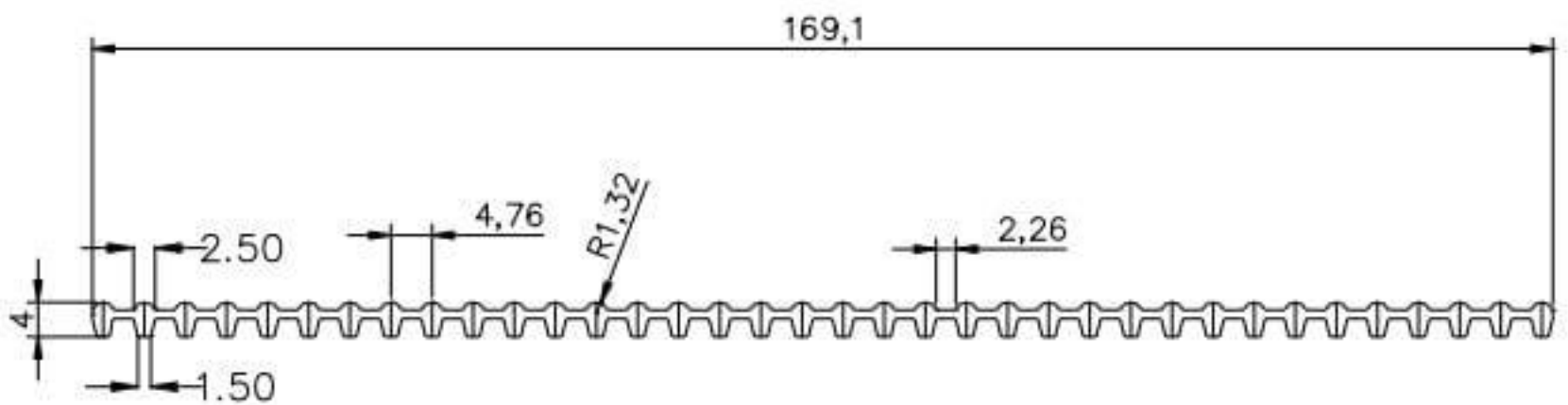
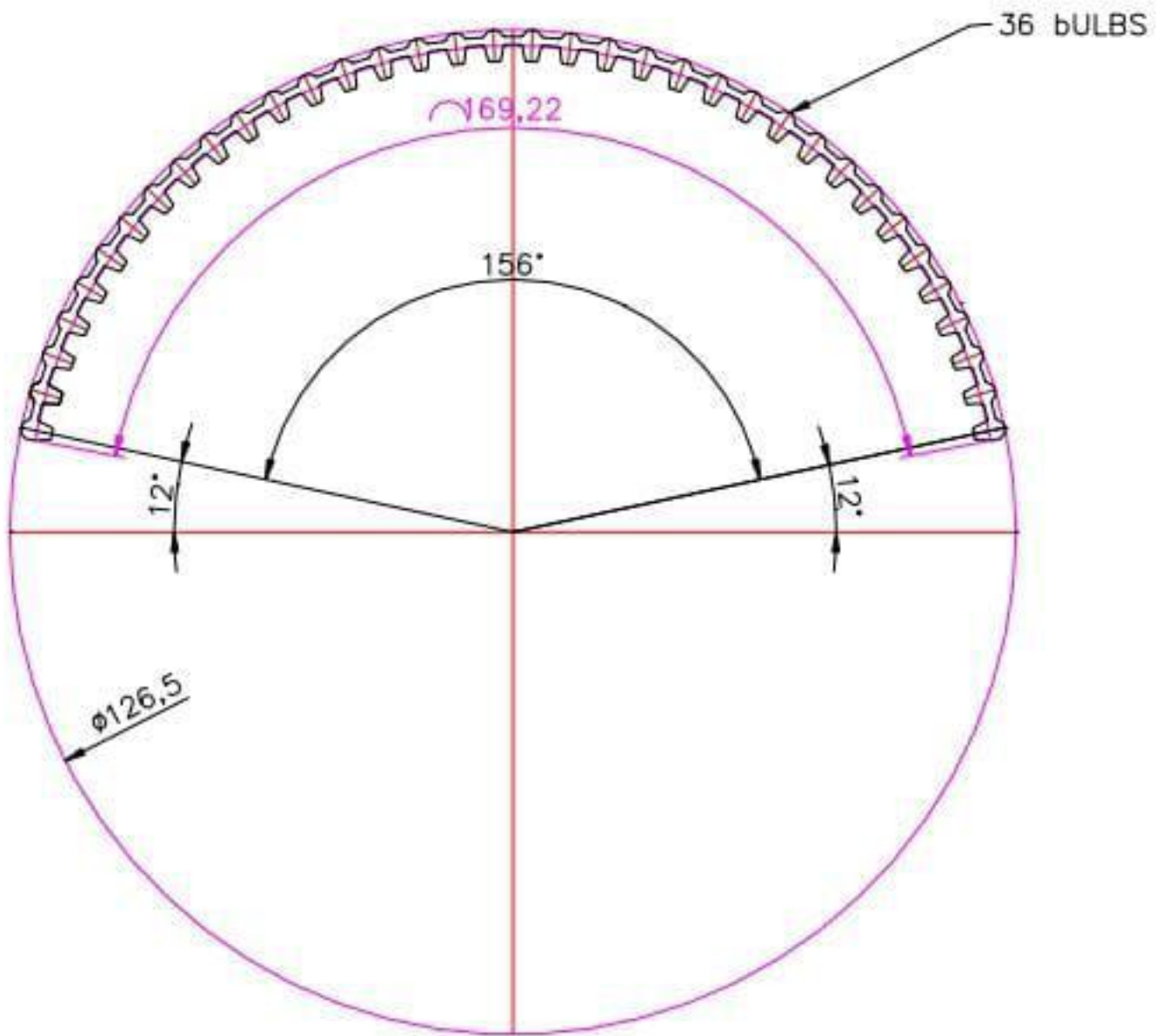

Twist: $1/4$ / 300 mm / meter

Straightness: 1.5 mm / meter

Angularity : $^{\circ}$ 2

All dimensions are in M.M.

Unspecified Corner Radius 0.25 m.m.

Wardhan Extrusion Sikar Raj.

Party sample/Drg.		Party Name		Grill Section 36 Bulbs	
				Drawn	Area 391 mm ²
				Checked	Weight 1.023 Kg/m
				Approved	
				Scale: 1:1	Date Alloy & TempeHE 9
				Critical Dim. *	
Revision Status	Rev. No.	Description	Sign. Date	Perimeter	Int. -
REVISION					Sec. No.